

8.3.1 TECHNICAL DATA

INTERNAL DIAMETER: 10 mm

MAX OPERATING PRESSURE: 400 BAR

WORKING TEMPERATURE: -20 ÷ 80 °C ("P" version with NBR seals)
-10 ÷ 150°C ("V" version with VITON seals)

SAFETY VALVE: see catalogue section 8.1

BURST DISK: see catalogue section 8.2

FUSE DISK: see catalogue section 8.2

MATERIAL: - phosphated or
- galvanized carbon steel in compliance with Directive 2002/95/EC (RoHS) to resist to corrosion
- stainless steel AISI 316L
- nickel coating 25-40 μ

MEDIUM: nitrogen (N₂)

WEIGHT: see table 8.3c

8.3.2 ADVANTAGES

- compact design
- flexible connection options
- the accumulator can be charged with nitrogen using PC kit , directly via standard or special filling valve.

8.3.3 DESCRIPTION

The gas side adapters are blocks of various type, which is possible to mount on the gas side of an accumulator and which can be fit many pressure devices, charging equipment, gas safety valve, burst disk, fuse disk, needle valve, pressure gauge, minimess and other components. Special seal allows this adapter to be installed simply and securely in any position on all gas valves of the bladder accumulators. It's important to select the correct adapter based on the thread of the gas valve.

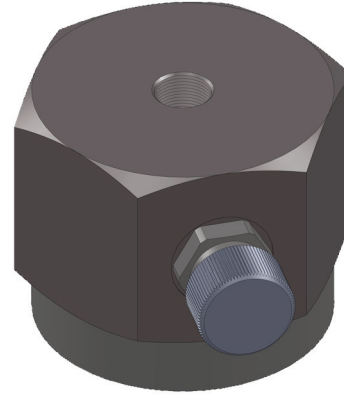

8.3a

8.3.4 HYDRAULIC SYMBOL

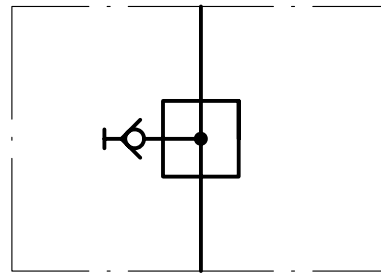

8.3b

8.3.5 MOUNTING

Before mounting a gas side supplied as individual item, you should fully discharge the nitrogen pressure inside the accumulator. The you should unscrew the existing pre-charge valve.
External valve

Internal valve
Use a wrench with code B2508

Now make sure the seal is correctly fitted into its seat inside the adapter on the threaded side

In order to mount the adapter on the valve of the accumulator, screw the adapter on the gas valve body of the accumulator and tighten with torque 80+20Nm.

If necessary, connect the various connections.

Pre-charge the accumulator as shown in the manual of use and maintenance.

8.3.6 ORDER CODE

1	2	3	4	5	6	7		
TG	50	P4	V	-	1G2	-	C	P

1	Series
Gas side adapter	= TG

2	Gas valve dimension
M50X1.5	= 50
M22X1.5	= 22
7/8" UNF	= 7/8

3	Top central connection
1/2" NPT-F	= P4
3/4" BSP male	= G5M
1/2" BSP female	= G4
Burst disk set at xxx bar	= Rxxx
Safety valve set at xxx	= Gxxx
1/4" BSP female	= G2
Connection for pressure gauge of 1/4" BSP	= M000
Pressure gauge dia. 63 mm with full scale xxx	= Mxxx
Ball valve of 1/2" BSP	= B4
Needle valve of 1/4" BSP	= N2
Stainless steel needle valve of 1/4" BSP	= N2X
Stainless steel ball valve of 1/4" BSP	= B2X
Needle valve of 1/4" BSP + cap	= N2T
1/4" BSP Plug	= T2
1/2" BSP Plug	= T4
N°1 exclusion device at 90° with pressure gauge dia. 63 mm with full scale xxx	= ELMxxx

4	Pre-charge valve (Lateral)
Valve of 5/8" UNF	= V
Stainless steel valve of 5/8" UNF	= VX
Valve of 7/8" UNF	= V4
Valve of 1/4" BSP	= V2

7	Seals material
Nitrile NBR	= P
Viton FKM	= V

6	Material
Carbon steel	= C
Nickel carbon steel 25 μ	= N
Nickel carbon steel 40 μ	= M
Stainless steel AISI 316 L	= X

5	Eventually lateral connections
No. 2 of 1/4" BSP	= 2G2
No. 3 of 1/4" BSP	= 3G2
No. 1 exclusion device with pressure gauge dia. 63 mm with full scale xxx	= 1EMxxx
No. 1 exclusion device at 90° with pressure gauge dia. 63 mm with full scale xxx	= 1ELMxxx
No. 1 of 1/4" NPT-F	= 1P2
No. 2 of 1/4" NPT-F	= 2P2
No. 3 of 1/4" NPT-F	= 3P2
No. 1 needle valve of 1/4" BSP	= 1N2
No. 1 stainless steel ball valve of 1/4" BSP	= 1B2X
No. 1 needle valve of 1/4" BSP + cap	= 1N2T
Fuse disk at xxx°C	= DFxxx

8.3.7 DIMENSIONS

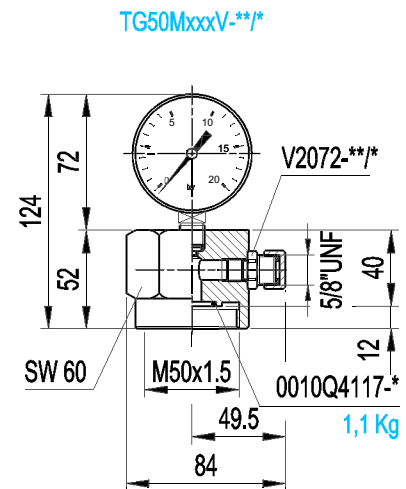
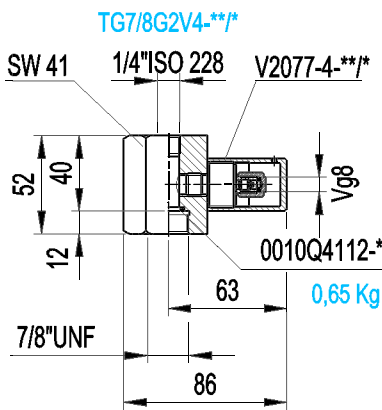
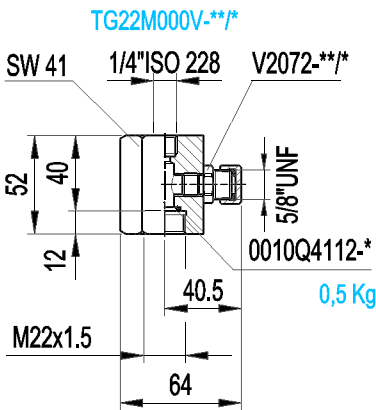
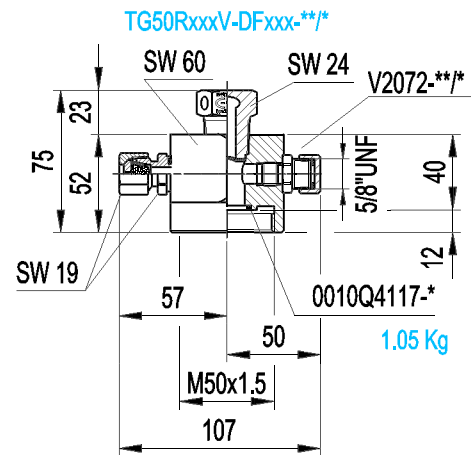
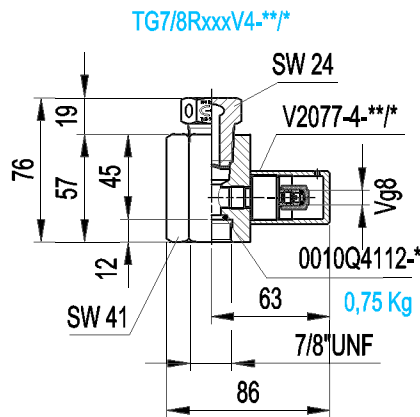
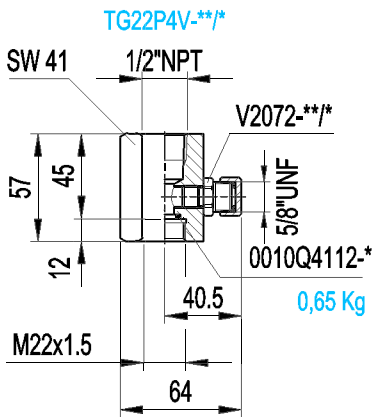
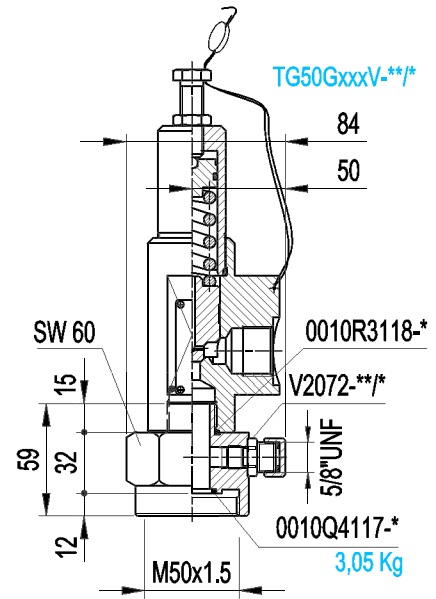
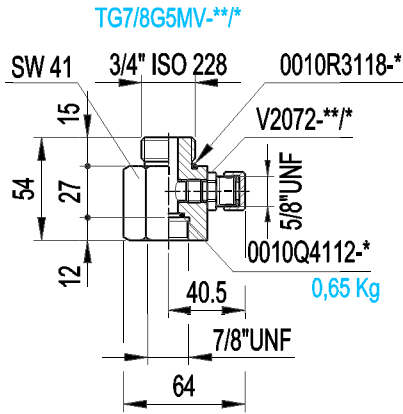
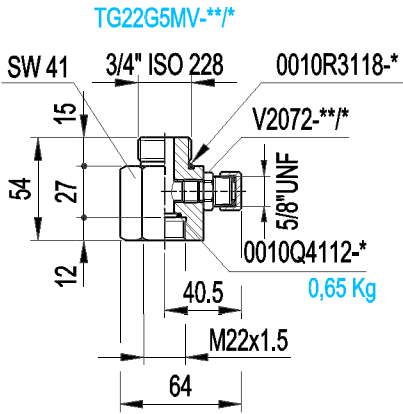

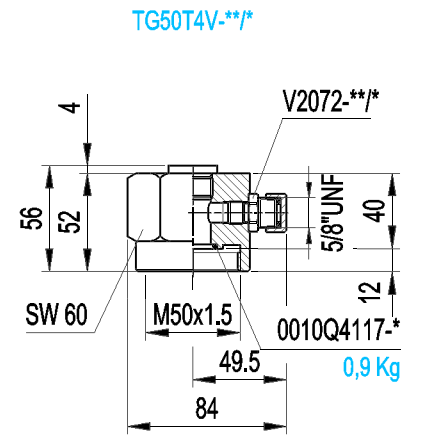
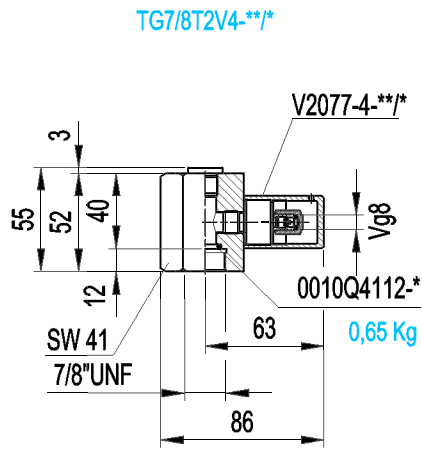
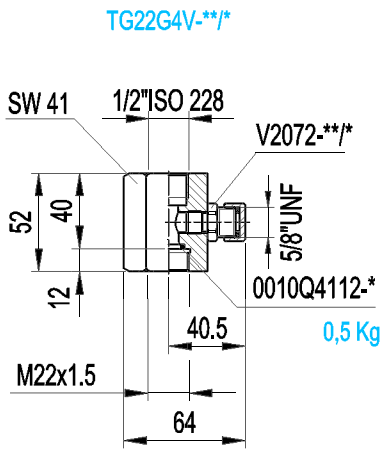
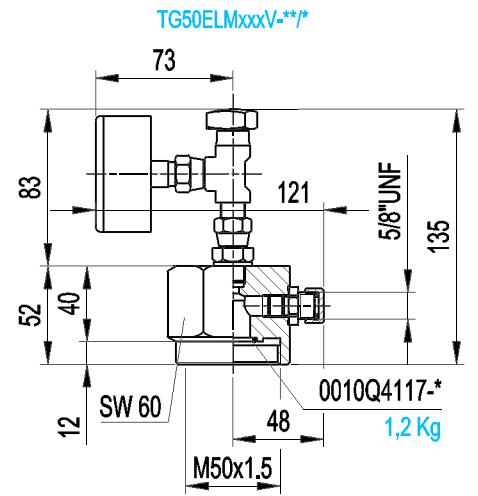
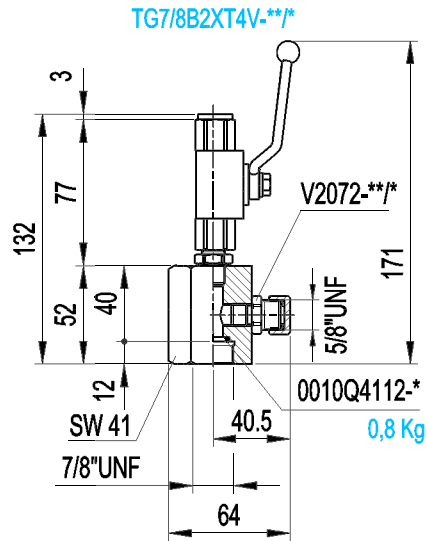
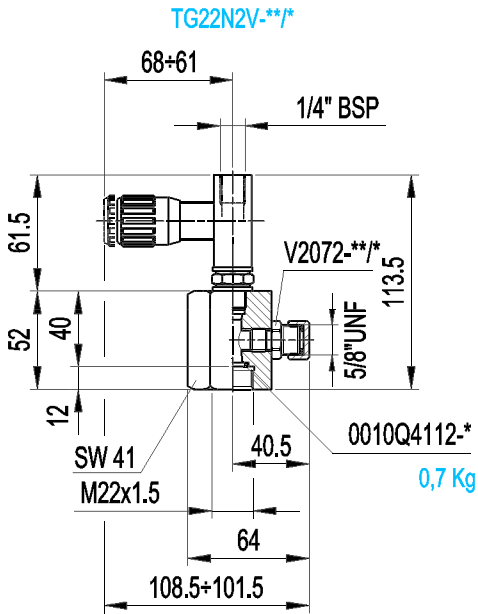

Reproduction is forbidden.
In the spirit of continuous improvement, our products may be changed.